

12V input & reverse polarity protection

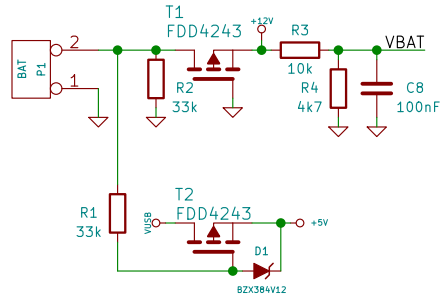

5V voltage regulator (buck)

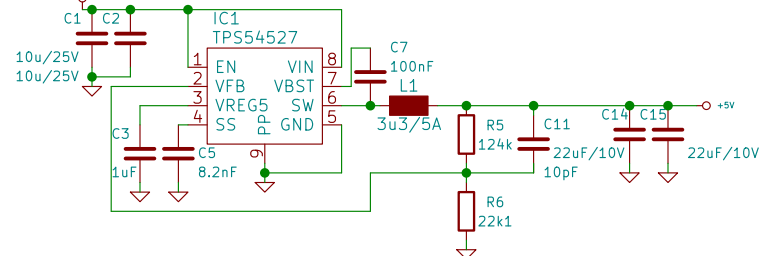

3V voltage regulator (LDO)

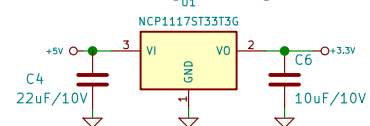

Arduino micro compatible controller

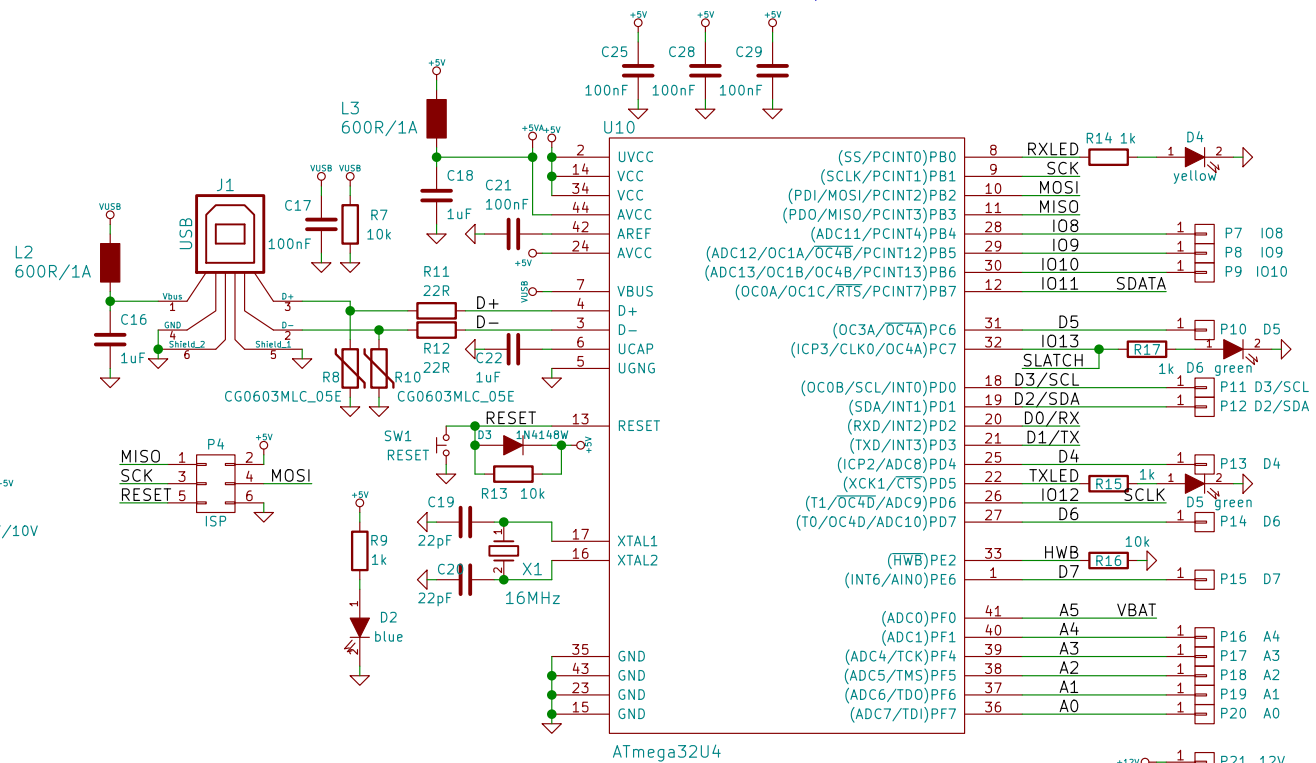

XBEE PRO 868 module

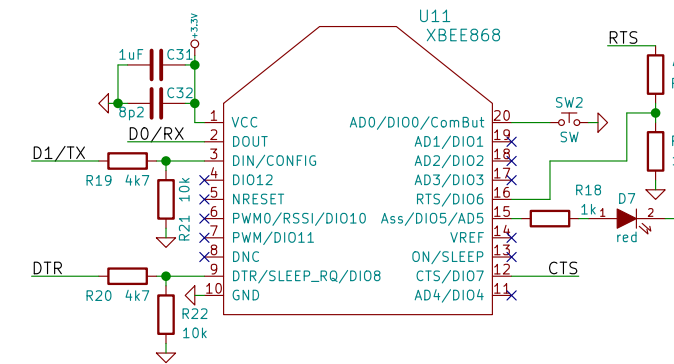

USB RS232 bridge (optional)

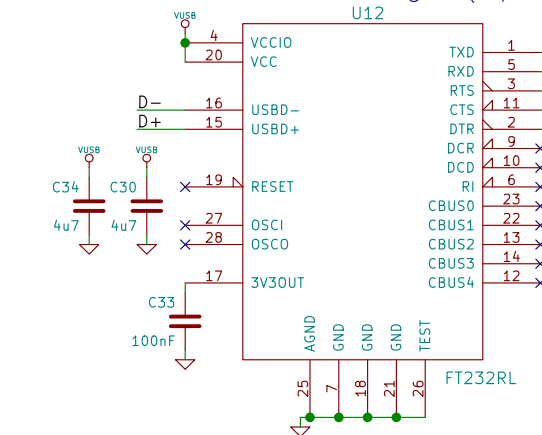

4x7 bit shift register & 350mA LED driver

